



Oifig Na  
bPaitinni

The  
Patents  
Office

## **IE 020664**

### **"SURGICAL STAPLING DEVICE"**

A surgical stapling device comprises a shaft (10), a surgical staple (14) slidable longitudinally within the shaft, and a staple-firing mechanism (16,24) for driving the staple towards the forward end of the housing, bending the staple to bring the free ends of the legs towards one another to close the staple, and releasing the closed staple. The device also includes a blood locator tube (18) slidable longitudinally within the shaft between an initial extended position wherein a forward end of the tube projects beyond the forward end of the shaft to enter a puncture site in a liquid-carrying vessel in a human or animal, thereby to locate the forward end of the shaft at the puncture site, and a retracted position wherein the tube is retracted into the housing in coordination with the closure of the staple. The tube (18) has a longitudinal slot (20) extending rearwardly from its forward end and the back of the staple is accommodated transversely in the slot. <Fig.3>

## Surgical Stapling Device

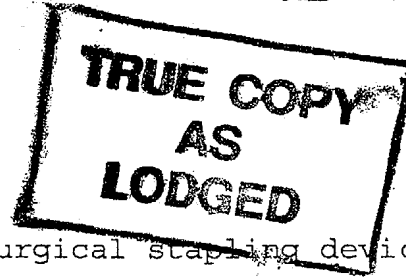

This invention relates to a surgical stapling device.

5 Surgical stapling devices have been in existence for many years. They are routinely used in surgical procedures mainly for the purposes of effecting a wound closure. Some of the most popular applications include closing a skin incision and end-to-end or end-  
 10 to-side anastomosis of internal (generally tubular) vessels such as the large bowel, etc. Current staplers are designed to deliver one or more staples in a serial fashion or a number of staples in one shot. Skin staplers, for example, deliver 30 or more staples in a  
 15 serial fashion. The staples are stacked within the device and during the firing operation one staple is advanced from the stack and delivered through the head of the device. During the following cycle another staple is advanced from the top of the stack and again  
 20 delivered through the head of the device and so on. In one shot devices such as a bowel anastomosis stapler the staples are prearranged in a linear or circular fashion and upon activation of the device all the staples are delivered through the head. Examples of  
 25 existing prior art as described above include US Patents 4,592,498, 5,289,963, 5,433,721 and 5,470,010.

The mechanism involved in forming a staple and releasing it from its forming mechanism is common to  
 30 the majority of surgical stapler devices. Generally the components include an anvil, a staple closing actuator, and a staple release mechanism. The anvil is

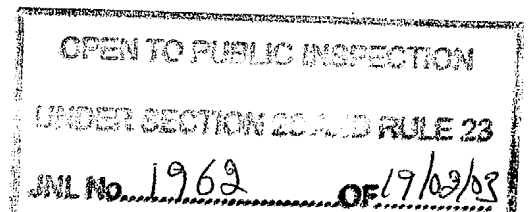
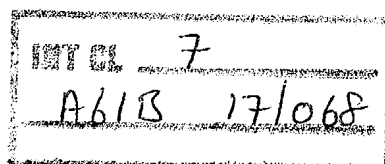

normally positioned in front of the staple and the actuator directly behind the staple. As the actuator advances the staple against the anvil the back section of the staple deforms around both ends of the anvil  
5 thereby transforming the staple from a generally U-shape to a generally rectangular shape. At this point the actuator generally retracts and the staple is released from the anvil either as a result of the anvil moving out of position and allowing the staple to move  
10 forward, or alternatively ejecting the staple over the anvil thereby releasing it from the device.

A mechanism such as that described above, used in conjunction with a blood location tube, is described in  
15 Irish Patent Application S2000/0722. This describes a stapling device which has a generally oval cross-section blood locator tube that protrudes ahead of the device. The function of the blood locator tube is to track down over a guidewire through the tissue and into  
20 the opening in the artery. Once in the artery, blood flows back up one side of the locator tube and exits the device outside the body where the operator can see it. This indicates to the operator that the device is in place and it is safe to operate. This patent  
25 application also describes a specially designed staple (humpback staple) which wraps around the locator tube so that it can be deployed centrally across the radial opening in the artery. The benefits of using an oval locator tube and a humpback staple are that the staple  
30 is located centrally in the artery and hence the staple used need not be so large, and in turn, the dimensions of the shaft, which must accommodate the staple when in its unformed state, can be reduced, leading to less

trauma to the tissue into which the shaft is introduced. A further consequence of having a generally oval or elongated cross section for the locator tube is that the tube will be more disposed to  
5 the center of the puncture than with a rounded tube. The device has a staple that straddles the locator tube, thereby increasing the likelihood of the staple closing the elongated wound at its center rather than towards one or other of the extremities of the wound.

10

The above device using a humpback staple has a number of disadvantages. When compared to conventional straight backed staples it can be appreciated that as the staple is formed around the anvil, the back is  
15 placed under tension, tending to cause the hump to collapse. In addition, because of the presence of the blood locator tube the anvil is reduced to individual fingers which tend to collapse inward due to lack of central support.

20

Furthermore, because of the position of the locator tube the staple former must be generally U-shaped in section so as to straddle it. Because of this the working fingers have a tendency to spread outward  
25 during the forming process.

It is an object of the invention to provide an improved surgical stapling device in which these disadvantages are avoided or mitigated, while retaining the benefits  
30 of centrally positioning the staple across the radial tear.

This object is achieved by the invention claimed in the appended claims.

An embodiment of the invention will now be described, by way of example, with reference to the accompanying drawings, in which:

Fig. 1 is a perspective view of the forward end of an embodiment of a surgical stapling device according to the invention;

Fig. 2 shows the device of Fig. 1 in exploded view;

Figs. 3 to 6 are perspective views of the device of Fig. 1 at successive stages of operation in firing a staple; and

Fig. 7 is a perspective view of the device at the point of staple release.

Referring initially to Figs. 1 to 3, a surgical stapling device comprises an elongated housing or shaft 10 having upper and lower halves 10a and 10b defining between them a longitudinal channel 12 for slidably accommodating a staple 14, a staple closing actuator 16 and a blood locator tube 18. (Only the lower housing half 10b is shown in Figs. 1 to 6 to reveal the internal components. Also, only the free forward end of the housing 10 is shown in the drawings, since that is where the invention lies in the present embodiment.) The rear end of the housing 10 is preferably formed with a pistol grip and the movement of the various components to be described may be effected by a trigger

acting through a cam system. Such an arrangement is described in Irish Patent Application S2000/0722 which may be readily adapted to operate the device of the present embodiment.

5

The blood locator tube 18 is, except for a longitudinal slot 20, of substantially the same construction as that described in Irish Patent Application S2000/0722. Thus it has a generally oval cross-section at the distal end and is slidable longitudinally within the housing 10 between an initial extended position (Fig. 3) wherein a forward end of the tube 18 projects beyond the forward end of the housing to enter a puncture site in a liquid-carrying vessel in a human or animal, thereby to locate the forward end of the housing at the puncture site, and a retracted position (Fig. 6) wherein the tube 18 is retracted into the housing in coordination with the closure of the staple.

20 The tube 18 serves two purposes. In use it is tracked along a guidewire (not shown) to bring the front end of the housing 10 to the site of a puncture wound, and it allows blood to flow back along the housing to the handle to permit the operator to see when the forward end of the housing has penetrated the wound. This is as described in Irish Patent Application S2000/0722. However, in the present embodiment the tube 18 has a longitudinal slot 20 extending rearwardly from its forward end partially along the length of the locator member. In this embodiment the slot 20 is about 5mm long. A pair of inwardly bent tabs 22 at the front end of the tube 18 confine the guidewire to the region of the tube below the slot 20 (referring to the

orientation seen in the drawings), to avoid the guidewire interfering with the movement of the staple and actuator within the slot, to be described.

5 The actuator 16 is an elongated member having a forward end which is forked to provide two arms 16a connected by a transverse bridge 16b. The bridge 16b extends transversely through the slot 20 with the arms 16a extending forwardly on either side of the tube 18. The  
10 rear of the actuator 16 comprises a pair of opposed part-cylindrical shells 16c which slidably embrace the tube 18 to allow the actuator 16 to slide longitudinally thereon.

15 The staple 14 is a standard, generally U-shaped staple having a straight back 14a and two forwardly pointing legs 14b. The free ends of the staple legs 14b are sharpened for ease of tissue penetration. In use of the device the back 14a of the staple is accommodated  
20 transversely in the slot 20 with its forwardly pointing legs 14b disposed externally of and respectively on opposite sides of the tube 18.

The device further includes an anvil 24. This is made  
25 out of stamped and bent metal sheet and comprises a pair of opposite parallel side plates 24a each with a laterally extending wing 24b, and a bridge element 24c joining the front ends of the side plates 24a. In use of the device the anvil 24 is fixed by its wings 24b in  
30 a recess 26 in lower housing half 18b with the side plates 24a disposed respectively on opposite sides of the tube 18 and the bridge element 24c extending transversely through the slot 20 in front of the staple

14. The bridge element 24c is substantially flush with the front surface of the housing 10. Finally, a pair of staple ejection springs 28 have their rear ends fixed respectively to the wings 24b and their free front ends, when unrestrained, extending upwardly above the level of the bridge element 24c.

The operation of the device will now be described with reference to Figs. 3 to 6.

10

In the initial configuration of the device, Fig. 3, the tube 18 is in its extended position wherein the forward end of the tube 18 projects beyond the forward end of the housing 10. The actuator 16 is retracted rearwardly and an undeformed staple 14 sits freely in the slot 20 just ahead of the arms 16a. The anvil bridge element 24c is in the slot 20 spaced ahead of the staple back 14a and flush with the front surface of the housing 10. All components are held in position by the top housing half 10a not shown in Figs. 3 to 6.

15

20

Upon operation of the trigger previously mentioned, or other operating mechanism, the actuator 16 is driven forwardly towards the free forward end of the housing 10. This drives the staple 14 before it by engagement of the actuator arms 16a with the outer portions of the staple back 14a. During such forward movement the staple deflects the free ends of the ejection springs 28 downwardly. At the same time the blood locator tube 18 starts to be retracted in coordination with the movement of the staple. Fig. 4 shows the positions of the components just as the back 14a of the staple reaches the fixed anvil bridge element 24c.

25

30



Deformation of the staple is about to take place at this stage.

Upon further forward movement of the actuator 16, Fig. 5, the staple is deformed around the anvil bridge element 24c, thereby bending the staple to bring the free ends of the legs 14b towards one another to close the staple in a generally rectangular shape.

10 Finally, Fig. 6, further retraction of the blood locator tube 18 clears the closed staple 14 to allow the ejection springs 28 to push the closed staple upwardly relative to the transverse bridge element 24c to release the staple. As seen in Fig. 7, the upper  
15 housing half 10a has a recess 30 at its front end to allow this upward movement of the closed staple.

The benefits of the foregoing embodiment over the device described in Irish Patent Application S2000/0722  
20 are:

a. A standard straight legged staple can be used. This will deform in a more predictable manner, it is less expensive to manufacture and is less likely to become  
25 caught in the anvil or shaft.

b. As the staple used is straight there is less risk that the staple will open up and create a "lazy" staple effect.

30 c. A larger blood locator tube can be used for ease of manufacture and increased blood flow for better indication of position.

d. Stronger and easier to manufacture anvil due to the transverse bridge.

- 5 e. Bridge between forming components of former to prevent spreading during the staple forming process.

Also it is possible to define a configuration which incorporates not one but two staples. Both staples  
10 would be located in respective slots on either side of the blood locator tube. A configuration such as this allows for the passage of a component such as a guidewire between both staples that would facilitate the process of blindly locating puncture holes in  
15 vessels.

The invention is not limited to the embodiment described herein and may be modified or varied without departing from the scope of the invention.

**Claims**

1. A surgical stapling device comprising an elongate housing having a free forward end, a surgical staple  
5 slidable longitudinally within the housing towards the forward end thereof, the staple having a back and two forwardly pointing legs, and a staple-firing mechanism for driving the staple towards the forward end of the housing, bending the staple to bring the free ends of  
10 the legs towards one another to close the staple, and releasing the closed staple, the device further including an elongated locator member slidable longitudinally within the housing between an initial extended position wherein a forward end of the locator  
15 member projects beyond the forward end of the housing to enter a puncture site in a liquid-carrying vessel in a human or animal, thereby to locate the forward end of the housing at the puncture site, and a retracted position wherein the locator member is retracted into  
20 the housing in coordination with the closure of the staple, wherein the locator member has a longitudinal slot extending rearwardly from its forward end partially along the length of the locator member, and wherein the back of the staple is accommodated  
25 transversely in the slot with its forwardly pointing legs disposed externally of and respectively on opposite sides of the locator member.

2. A device as claimed in claim 1, wherein the  
30 staple-firing mechanism comprises an actuator slidable longitudinally of the housing within the slot for driving the staple towards the forward end of the

housing, and an anvil against which the staple is driven by the actuator to deform and close the staple.

3. A device as claimed in claim 2, wherein the anvil  
5 comprises an element extending transversely through the slot in the locator member in front of the staple, the forward end of the locator member being positioned behind the said transverse member in the retracted position of the locator member to allow release of the  
10 closed staple.

4. A device as claimed in claim 3, further including resilient biasing means for pushing the closed staple upwardly relative to the transverse element to release  
15 the closed staple.

5. A surgical stapling device, substantially as described herein with reference to Figs. 1-7 of the accompanying Drawings.

1E020664

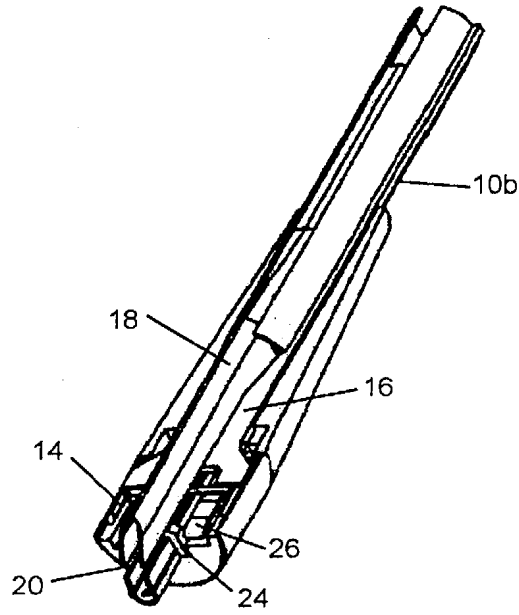

Fig. 1

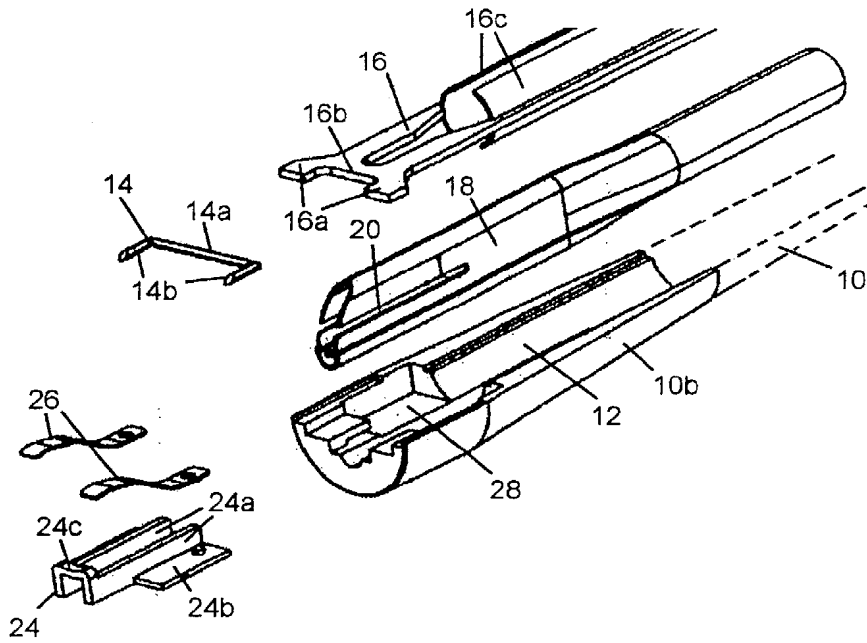

Fig. 2

IE 0 2 0 6 6 4

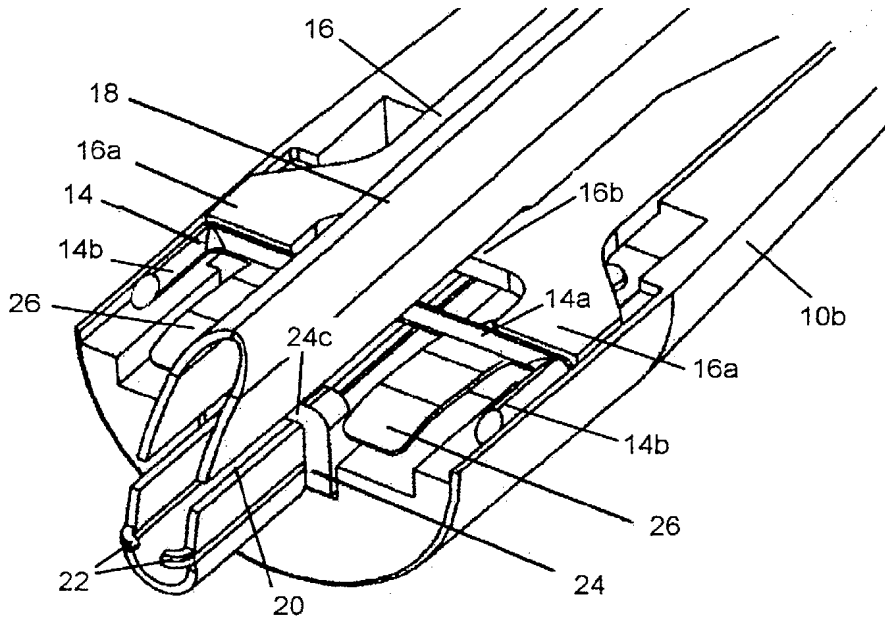

Fig. 3

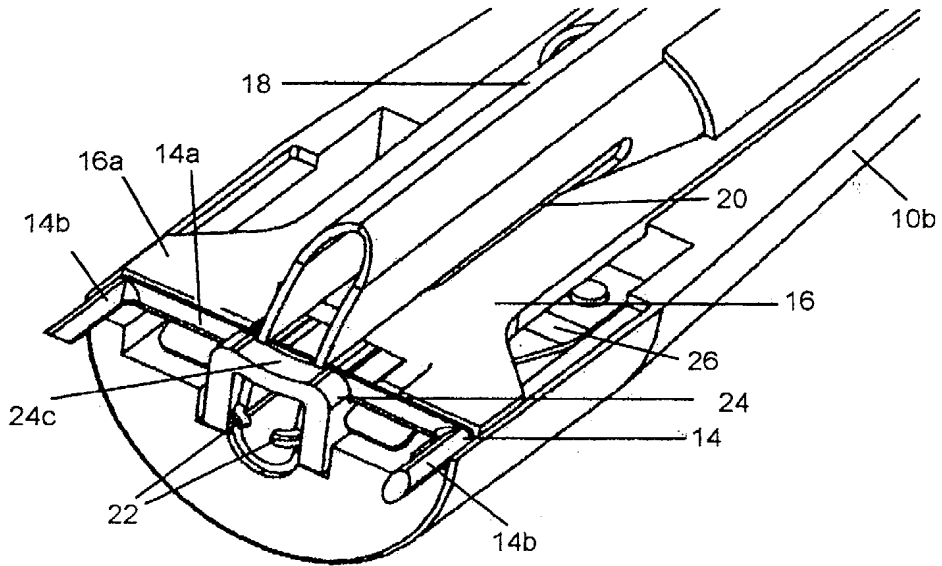

Fig. 4

IE 0 2 0 6 6 4

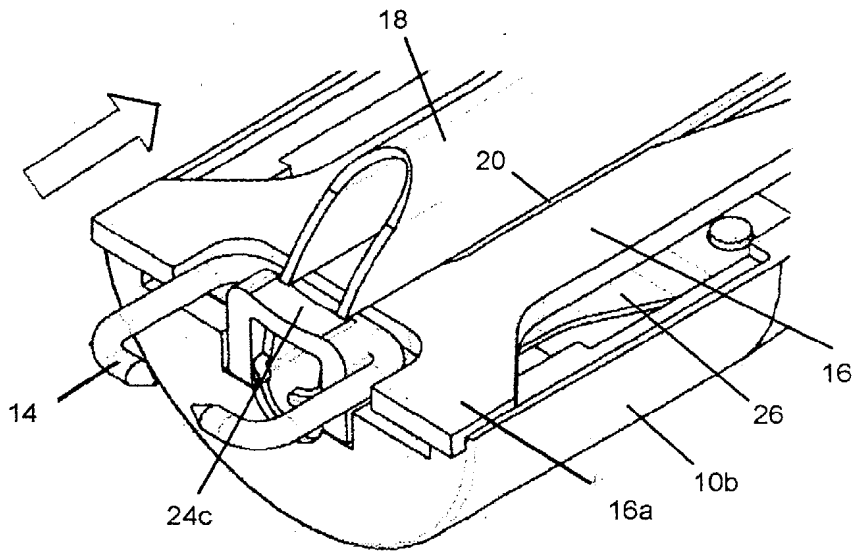

Fig. 5

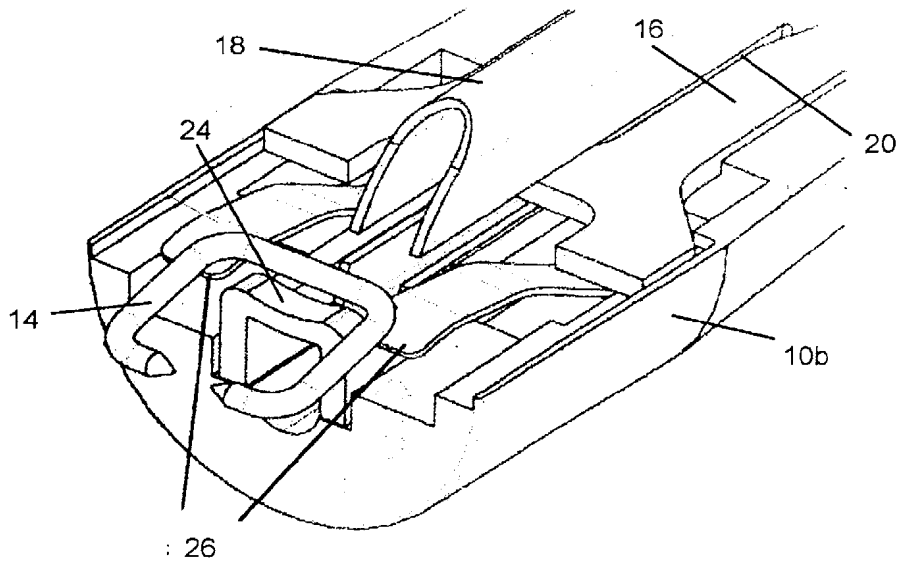

Fig. 6

IE 0 2 0 6 6 4

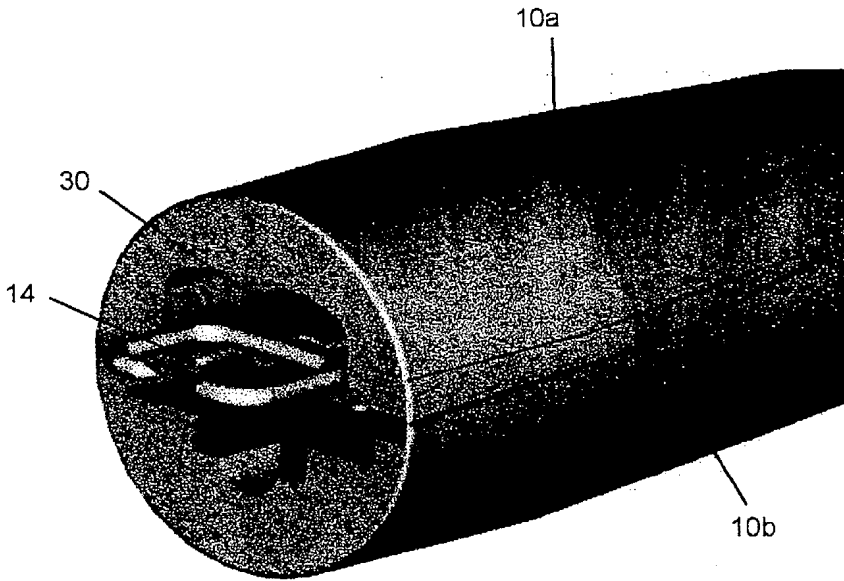

Fig. 7